

Skytile Surface Mount Trays

Installation instructions

Warnings & Cautions

- It is recommended that these products are installed by a competent person.
- Do not install in areas that are exposed to continual running water or prone to flooding.
- Ensure that the mounting surface is both flat and stable.
- Any broken or damaged parts should be replaced as soon as possible.
- JCC will not accept responsibility for claims arising from sub-standard installations
- These products are suitable for indoor use only.
- These products are designed for use with the JCC Skytile Recessed LED panel Ranges

INSTALLATION

ENGLISH

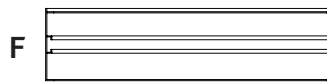
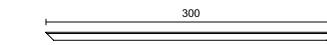
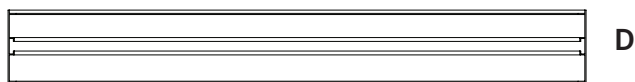
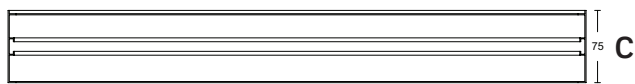
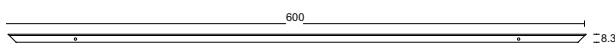
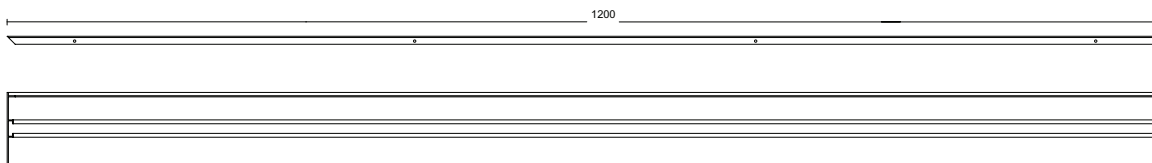

Component	Description	600 x 600 QTY	1200 x 600 QTY	1200 x 300 QTY
A	Ceiling Mount bracket with M3 x 4mm fixing screw	4	8	8
B	Corner Bracket (comprises of 2 parts) (1 x inner / 1 x outer)	4	4	4
C	600mm Side panel with Ceiling Mount bracket fixing hole	2	0	0
D	600mm end panel	2	2	0
E	1200mm Side panel with Ceiling Mount bracket fixing hole	0	2	2
F	300mm end panel	0	0	2

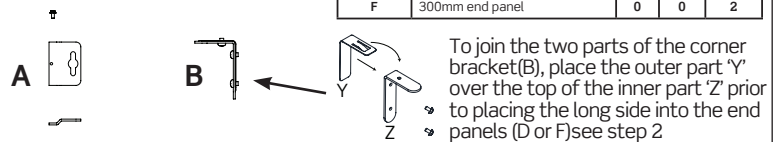

Step 1.

Fit the 4 ceiling mount brackets to both of part C, 600mm Side panel or 8 brackets to part E 1200mm Side panel with Ceiling Mount bracket fixing hole.

Place bracket underneath the lip and align the threaded hole in the bracket with the hole in the top of the side panel and fix with the M3 x 4mm pan head screw

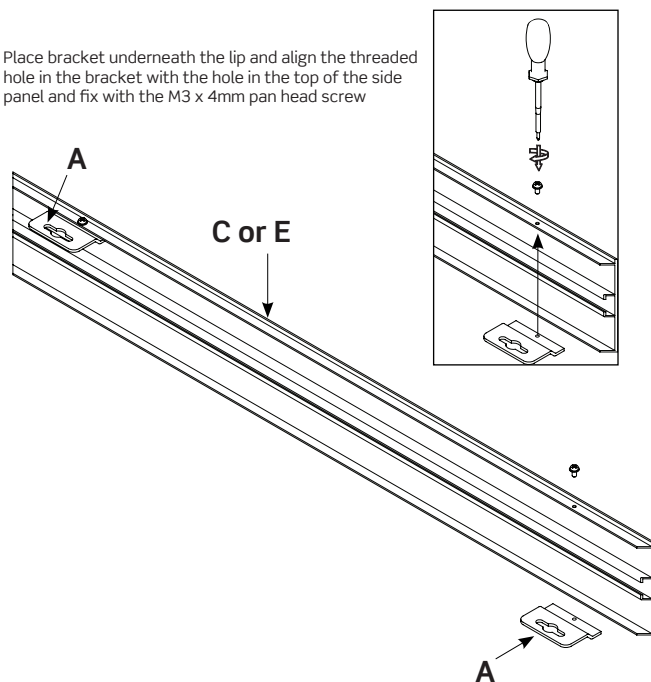

Step 2.

Fit the 4 corner brackets part B to part D, 600mm End panel or part F 300mm End panel. Ensure to fit the long side of the bracket into the panel and tighten the two screws (do not tighten the single screw of the short side of the bracket)

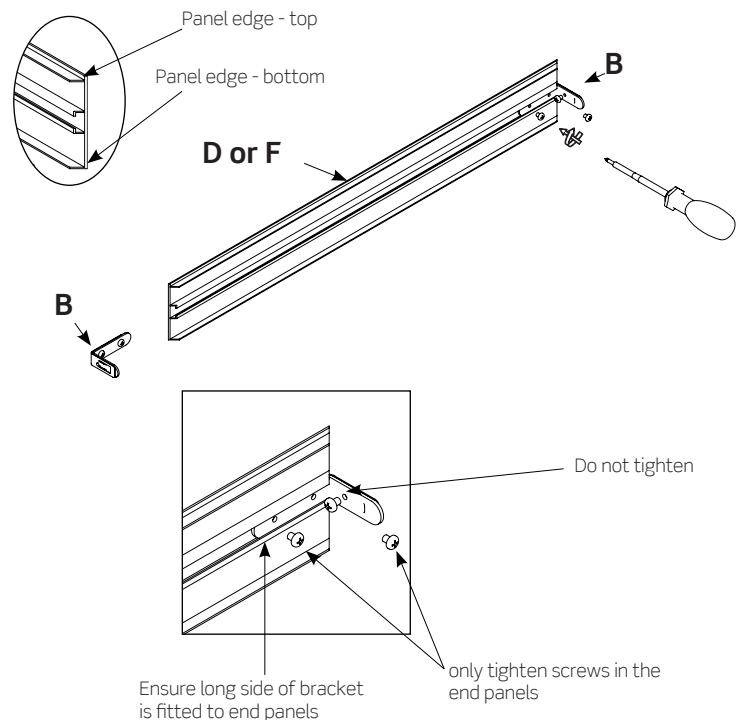

Important warranty information

This product is supported by a 2-year standard warranty. (See website for terms and conditions).

CE UK RoHS IP20 jcc.co.uk
Compliant

BS EN ISO9001 - 2015 - Registered Firm Certificate No. GB 1552

JCC Lighting Products Ltd. Innovation Centre, Beeding Close, Southern Cross Trading Estate, Bognor Regis, West Sussex, PO22 9TS, United Kingdom

Technical Support: +44(0)1243 838986 Customer Services: +44(0)1243 838999

V2_Aug_2021_RS

Step 3.
Slide the two side panels (C - 600mm or E- 1200mm) onto the corner brackets (B) that are already fitted to the end panel (D or F) and tighten the screw to secure the bracket to panel C.

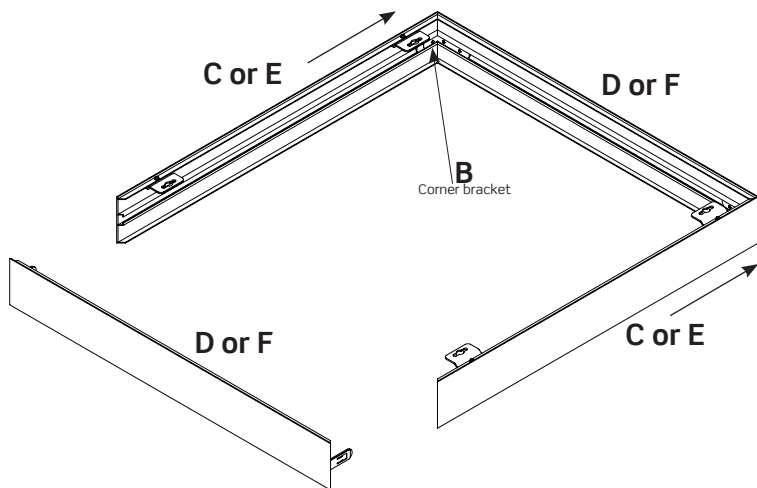

Step 4.
To ensure that the Surface Mount box is square when installing on the ceiling, you must now install the final end panel. The screw in the short end of the bracket must only be finger tight. This may need adjusting to ensure the bracket is expanded to allow for an interference fit.

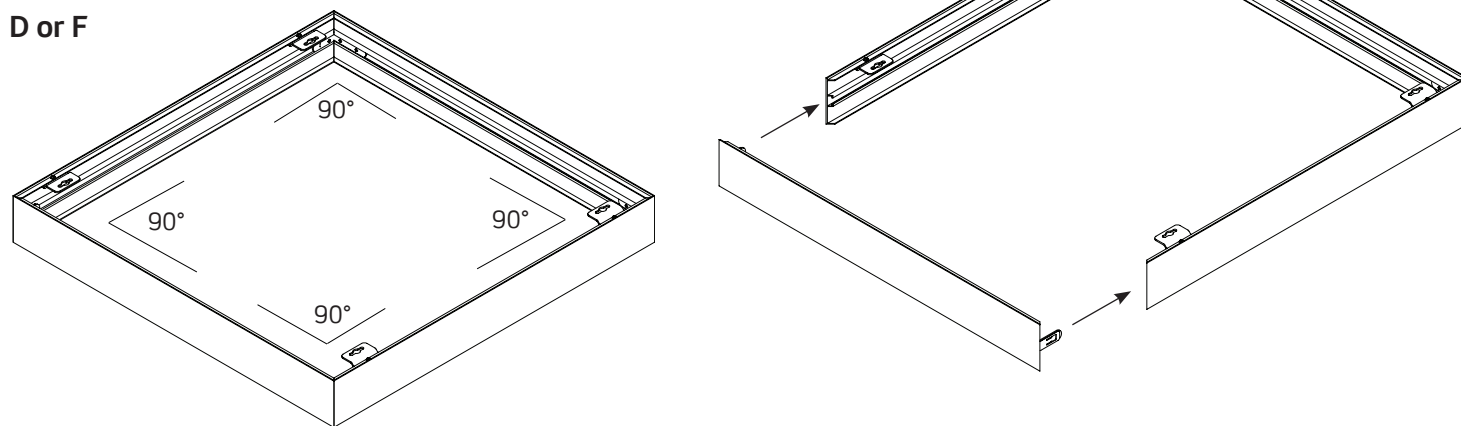

Step 5.
Make sure all four corners are square, then use as a template to mark the ceiling and the secure using suitable fixings.

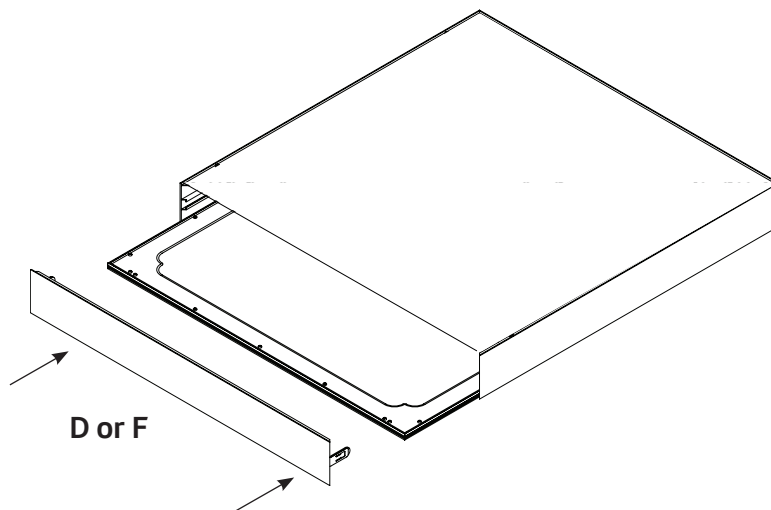

Step 6.
Remove the end panel D or F and fit the LED panel into the Surface Mount Box, connect the LED panel to the power supply as per the product instruction and then ref-fit the end panel D, ensure the screws on each bracket are adjusted to ensure a tight fit.